

CONTROLS

CONSTRUCTION
MATERIALS
TESTING

AUTOMAX^{ULTIMATE}

Automatic stand-alone
control console for concrete,
cement and steel testing



www.controls-group.com

AUTOMAX^{ULTIMATE}

AUTOMAX^{ULTIMATE}

Ergonomic and Automatic Computerized Control Console for cement, concrete and steel rebar testing allowing modular upgrades from basic failure tests to advanced displacement controlled tests for high-performance building material.

Connect up to four frames

You can connect your console to up to four testing frames, from 15 to 5000 kN in compression and 500 kN in tension, making it possible to test any kind of material and sample dimensions.

Compliant to the most important Standards

ISO 6784 | EN 12390-4 | EN 12390-13 |
EN 1338 | EN 14651 | EN 1488-3 |
EN 14488-5 | ASTM C469 |
ASTM C39 | ASTM C1550 |
ASTM C1609 | UNI 6556 | UNI 11039-2 |
BS 1924:1 | DIN 1048 | UNE 83515



Ultimate ergonomic design

User comfort and testing efficiency have been our priority when creating the AUTOMAX Ultimate. You can easily adjust its height and move the machine to your desired location ensuring that

you work in a comfortable work environment and make the most of your lab's space. Flexible, each operator can adjust it individually in a few simple steps. Flexible arm for PC is optional.

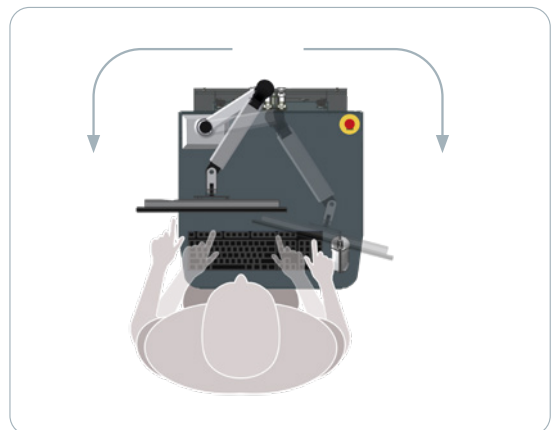

Ultimate Benefits

Maximum testing power by adding suitable accessories and enabling dedicated software modules.

Double stage Hydraulic Power Unit with rapid approach, soft platen-to-specimen contact and precise oil flow control allowing high throughput of precision-tests (up to 40/hour).

Ultimate control achieved by a high-frequency (1 kHz) closed-loop PID control which adjusts oil flow every millisecond.



Dedicated software packages

Console supplied with DATAMANAGER software for standard failure test and optional modules (E-Module, UTS and D-Control) for advanced test.

Easy of maintenance

Automatic software calibration procedure.

Connectivity-ready

Ready to connect with cloud-based software, able to transfer all tests data to the client's LIMS or to our CONTROLS' cloud system, allowing users to review and share the test results with third parties anywhere in the world.

REV-UP YOUR TESTING SYSTEM

The AUTOMAX Ultimate control console will convert any frame, from any brand, into an automatic system that meets the demands of 21st century concrete and cement testing.

Rev-up your testing system with additional frames, accessories and dedicated software packages

What we need to know

- ☑ Frame capacity
- ☑ Piston diameter or max working pressure
- ☑ Piston travel
- ☑ Piston type (single or double effect)



Intuitive Advanced Testing

Displacement Controlled tests

AUTOMAX Ultimate is the result of almost 20 years of research and cooperation with academic world and industries, in which we have — test after test — improved the system to an ultimate level of accuracy in the field of high pressure hydraulic machines.

AUTOMAX Ultimate allows the fully automatic test execution achieved by PID control suitable for any Stress-Strain tests.

Why perform Displacement-controlled tests?

These tests are mainly performed to determine the ductility of advance construction materials, used for their superior capability to deform after first concrete matrix cracking.

These materials include:

- FRC (Fiber-Reinforced Concrete)
- Shotcrete
- Structural specimens reinforced with carbon fiber fabrics or similar
- Composite materials

How it works

Load applied to the specimen is gradually increased in order to produce a constant rate of deformation up to the peak load value and first cracking.

Afterwards, load is gradually decreased until a certain level of deformation is achieved by the specimen.

The typical test result is the area subtended to the Stress-Strain diagram. Higher areas are obtained with materials with high ductility and toughness.

What system do you need?

Testing system must have very fast reaction times and extremely accurate oil flow regulation to face the typical instability of the post-peak stage.

It must also be able to control the rate of sample deformation, avoiding an early specimen failure and consequent loss of test results.

Automatic intuitive and reactive

Fully automatic

The test is carried out fully automatically, requiring no user intervention during testing, so that even less experienced technicians can complete the most complex tests.

Intuitive

Test profiles are already set up making it easy for the user to follow step-by-step instructions according to the most important Standards as below:

- EN 14651
- EN 14488-3
- EN 14488-5
- UNI 11039-2
- ASTM C1550
- ASTM C1609
- UNE 83515

All test results are calculated automatically according to the above Standards.

Fast-Reactive

The improved closed-loop PID control is lightening-fast, adjusting the oil flow every millisecond in order to react to any unexpected behaviour of the most critical specimens.

Research-Friendly

Users can create custom test procedures that can be carried out under load/stress/ displacement or strain control with the possibility to change in real time the test parameters:

- target load/displacement
- control variables
- test speed



Displacement Controlled tests

Modular

By adding accessories from the wide range available, coupled with dedicated software modules as D-Control, the console will be equipped to perform several tests complying with the main international Standards such as:

- Energy absorption test on square slabs to EN 14488-5
- Flexural toughness of round panels to ASTM C1550
- Deflection test on Steel Fiber Reinforced Concrete beams to EN 14651 (CMOD Method) and to UNI 11039 (CTOD method)
- Flexural behavior of FRC beams to ASTM C1609

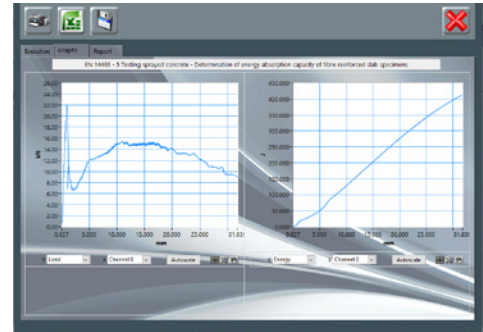

Energy absorption test on square slabs to EN 14488-5

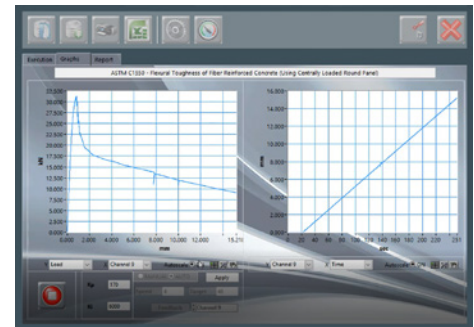

Flexural toughness of round panels to ASTM C1550

D-Control software package is the module for Displacement Controlled Tests allowing:

- 8 test pre-set testing procedures according to EN 14651, 14488-3, 14488-5, UNI 11039-2, ASTM C1550, C1609, C947, UNE 83515
- Automatic calculation of test results according to the above Standards
- Customizable test procedure allowing desired loading history
- Possibility to change in real time the test parameters: target load/displacement, control variable, test speed

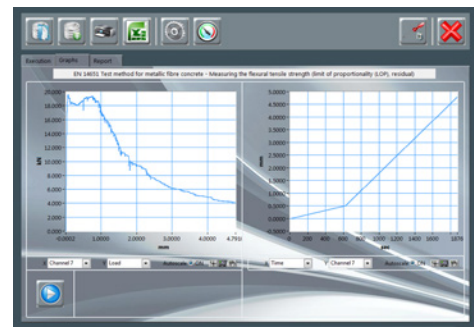
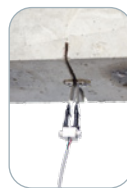

Deflection test on Steel Fiber Reinforced Concrete beams to EN 14651 [CMOD Method] and to UNI 11039 (CTOD method)

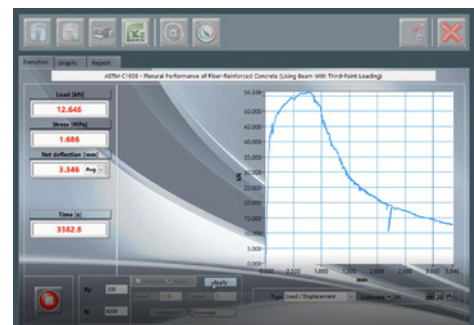

Flexural behaviour of FRC beams to ASTM C1609

Intuitive Advanced Testing

Elastic Modulus and Poisson's Ratio determination

Assessing the Elastic Modulus (or Modulus of Elasticity-MoE) value of concrete, reflecting its ability to deform elastically under a given load, is becoming increasingly widespread.

In fact, in recent years, we have seen an increased demand to meet a minimum Elastic Modulus value to avoid excessive deformations and sway in structures, such as skyscrapers and bridges. These are only allowed to deflect by a certain margin in order to fulfill serviceability and safety requirements.

How it works

The specimen is subjected to a sequence of loading and unloading cycles under controlled loading/unloading rate, meanwhile acquiring specimen axial deformation. Lateral deformation is important to be measured only when also Poisson's Ratio is required.

Automatic calculation of Elastic Modulus and Poisson's Ratio values



Free, unlimited programmable load/stress cycles to fulfil any kind of test procedure.



Real-time monitoring of test data, stress/time, stress/axial strain, stress/lateral strain graphs.



Automatic verification of sample positioning and sensors functionality, as per Standards requirements.

The AUTOMAX Ultimate console allows the fully automatic control of the whole loading/unloading steps sequence and strain measurement in MoE and Poisson's Ratio tests. The E-Module software package automatically calculates test results and generates test reports for easy analysis.



In-built automatic procedures according to:

- EN 12390 Method A and B
- ASTM C469
- ISO 1920-10
- EN 13286-43 Indirect tensile and Compression
- EN 13412 – Method B

Easy Steel Rebar Tensile Tests

Automatic tests on steel rebars

AUTOMAX Ultimate can also perform with ease tensile testing on steel rebars up to 26 mm diameter and flats up to 13 mm thickness.

Suitable for education and general laboratories

The tensile frame is lightweight and compact, with good accuracy level at low cost, making the system ideal both for educational purposes and laboratories needing a simple machine for testing small steel samples.

Fully compliant with the latest release of EN Standards, the system can conduct the test up to yield, controlling the rate of stress (method B) or strain by using an extensometer (method A1) or by using the crossheads' movement (method A2). After the yield occurs, the test is performed under crossheads' movement control.

Real-time monitoring

Thanks to the UTS-Software package, during the test it is possible to see all test parameters in real time and overlap two elongation / stress graphs: one obtained with the displacement transducer measuring crosshead travel, the other obtained with an extensometer (if used).



Automatic calculation of results

At the end of the test, results are automatically calculated in full compliance with EN ISO 6892-1 and EN 15630-1 and automatically exported into either *pdf* or *excel* formats.



Smart Connectivity

Quality testing for modern laboratories

AUTOMAX Ultimate introduces, via DATAMANAGER software, new features and capabilities that will revolutionize the operations of any modern laboratories.

LinkLAB

LABORATORY CONNECTIVITY PACKAGE

LinkLAB is CONTROLS' proprietary Laboratory Connectivity Package that brings total reliability and transparency to your testing process. It allows your machine to take direct inputs from many ancillary devices (caliper, digital balance and barcode reader) reducing error-prone manual tasks and eliminating transposing errors.

The Barcode Parser Protocol, instead, allows to get all the sample information needed just by scanning a barcode.

TESTVIEW^{PRO}

The addition of an integrated smart camera for recording your testing ensures that you can deliver unadulterable results that can be easily documented and shared.



Link-LAB Enterprise

Available for new and existing systems controlled by PC via DATAMANAGER Software.

✈ Basic Sample Information Acquisition

Direct acquisition provides a tidier operation, eliminating the possibility for data transposition errors.

Compatible devices include, but are not limited to:

- ➔ calipers
- ➔ digital balances
- ➔ ID bar-code readers

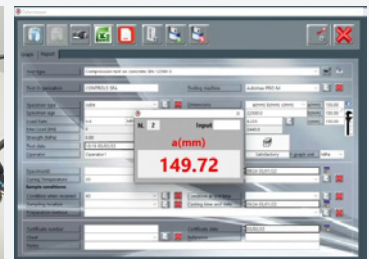

📌 Advanced Sample Information Acquisition

Where the barcode has a specific structure due to embedded sample information, it is then possible to transfer automatically the sample information from the barcode strips into the Datamanager software, by just flashing the barcode with the reader.

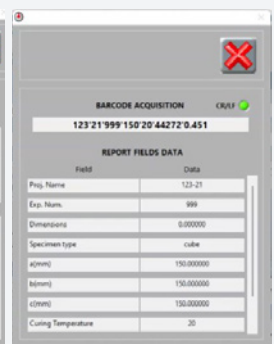
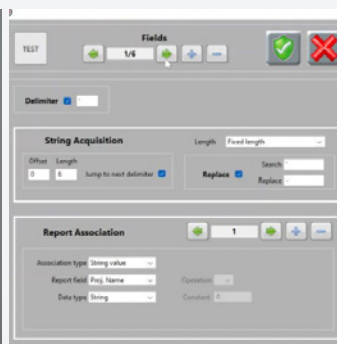

TESTVIEW **PRO**

High-resolution test recording

AUTOMAX Ultimate, via DATAMANAGER software, can connect and communicate with a high-resolution smart camera fitted to the compression machine, it can record all your tests, providing a verifiable audit trail.

How it works

Simply start the test by pressing the START button.

During the test, load, strength and time values are displayed in real-time along with stress versus time or load versus time graph.

The video recording is a fundamental tool to get transparency: not only it proves the test has been performed on that specific sample, but it also provides trustworthy test results as the load and strength values are displayed in real-time and watermarked.

When the sample fails, the machine will automatically stop and the video recording will be automatically compressed and saved along with the test results in the software's archive, ready to be then exported in .avi format and consulted by third party engineers, clients, head-office, etc.

Sample ID Reader (SID Reader)

You can also upgrade to get the extra SID READER software module that will allow the smart camera not only to record the test, but also to read and recognize the barcode on the sample.

With SID READER enabled, before testing begins, the DATAMANAGER software connects to the smart camera to ensure the barcode on the sample matches the ID number previously entered.

The ID number will be then watermarked in the video, along with the date, time, elapsed time, load and strength values, providing traceable and transparent test results.



TESTVIEW PRO with rigid arm (optional) on a compression frame

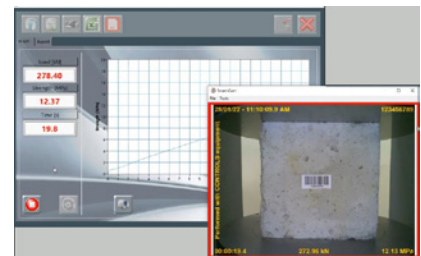

Test results displayed in real time and watermarked

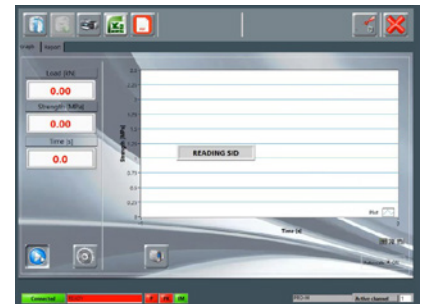

Reading and recognition of the sample barcode



Five key benefits

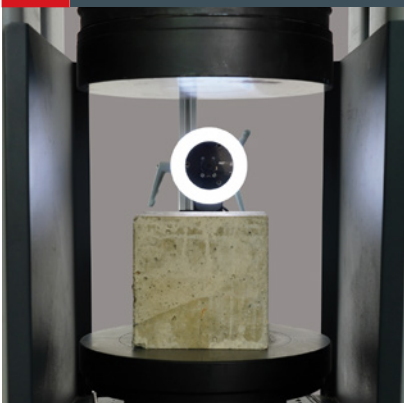

- It proves the test has been performed on that specific sample
- It provides trustworthy test results as load and strength values are displayed in real time and watermarked
- Recordings can be automatically saved to be viewed, consulted and shared with 3rd parties
- Smart camera recognizes the barcode on the sample (with SID Reader enabled)
- Video recordings, along with test results, are compressed and safely saved in the software archive, ready to be consulted in case of any dispute on test results

Ready to connect

Take control of your data

AUTOMAX Ultimate, via DATAMANAGER, is ready to be connected to CONTROLS Connect cloud services, providing:

- **Better communication with any LIMS** through JSON protocols, allowing easy and automatic storing of each test in the laboratory database. No more human error and waste of time in transferring the information.
- **Cloud storage** with different access level of every test performed, results and reports: as soon as the test is stored, you can gain access to the report from anywhere in the world.

 **Contact our experts for more information**



MOST AUTOMATED MACHINES AVAILABLE

Thanks to our experience and leading technology, we have the ultimate automated test execution – just press the START button!



AUTOMATIC COMMUNICATION TO LIMS

Our machines will automatically send test results to your own LIMS system, so your testing database is always up-to-date.



AUTOMATIC REPORTING

PDF reports are automatically generated and saved after each break without any additional interventions from the operator's side, minimizing the risk of errors.

Specifications

How to order and upgrade your system

Technical Specifications

Hydraulics

Dual stage HPU: centrifugal low pressure for fast approach with automatic switching to radial multi-piston high pressure for loading

DC motor: 720 W, 50-60 Hz

Maximum working pressure: 700 bar

Third and fourth frame option, active frame selection by software

Flow-sharing technology to perform loading and unloading cycles

ES Energy Saving technology to reduce power consumption and silent operation

Hardware

131.000 points effective resolution

High frequency closed-loop: P.I.D. control

Control frequency: 1 kHz

Sampling rate: 250 Hz

4 channels for load sensors (pressure transducers and load cells)

6 channels to measure strain values with transducers (LVDT, magnetostrictive, potentiometric)

4 channels for strain measurement

with strain gauges, LDT, clip gauges

Memorization of the calibration curve enables sensors to be connected and used immediately

Ordering Information

50-C20L82

AUTOMAX Ultimate stand alone power and control console for the control of up to 2 (expandable to 4) testing frames. PC included. 230 V, 50-60 Hz, 1 ph

50-C20L84

Automax Ultimate stand alone power and control console for the control of up to 2 (expandable to 4) testing frames. PC included. 110 V, 60 Hz, 1 ph

PC and Software

50-SW/DM (included)

Software module for compression, indirect tensile, 3 points and 4 points flexural tests on different types of specimens

50-SW/EM

Software module for Elastic modulus and Poisson's ratio determination

50-SW/DC

Software module for Displacement Controlled Tests to EN 14651, 14488-3, 14488-5, UNI 11039-2, ASTM C1550, C1609, UNE 83515 or customizable test procedures

50-SW/UTS

Software module for Steel Tensile Testing

Upgrading Information

50-C10D/3F

AUTOMAX System upgrade for a third frame connection and control. Frame selection will be made via PC

50-C20E/4F

AUTOMAX System upgrade for a fourth frame connection and control. Frame selection will be made via PC

50-KLAB/E

Link-LAB Enterprise laboratory connectivity package for machines controlled by PC via DATAMANAGER Software

50-D1950/SM

High resolution integrated smart camera with flexible arm

50-D1950/RA

Rigid arm for TESTVIEW PRO smart camera

50-D1950/K

Barcode reader

50-D1950/SR

SID READER software module allowing the smart camera to read and recognize the barcode. To be purchased along with D1950/SM and D1950/K (optional)

50-D1650/200K

200 mm digital caliper

50-D1650/K1

Bluetooth emitter for caliper

50-D20L827/FA

Flexible arm for Ultimate PC

CONTROLS Customer Care

As one of the longest established manufacturing companies in the world of Construction Materials Testing solutions, we are dedicated to supplying high quality, accurate, affordable, easy to use systems.

As a valued customer of CONTROLS, you will receive continuous, expert support and advice for your equipment. Furthermore, we can offer full installation and training in the correct operation of your CONTROLS equipment.

For support from our expert Customer Care Team, contact your local CONTROLS office / distributor or email customercare@controls-group.com.

For more information, please visit www.controls-group.com.

CONTROLS

Italy (HEAD OFFICE)

t +39 02 92184 1

f +39 02 92103 333

e sales@controls-group.com

www.controls-group.com

France

info-fr@controls-group.com

Mexico

info-mx@controls-group.com

Poland

info-pl@controls-group.com

UK

info-uk@controls-group.com

USA

info-usa@controls-group.com